

THIS DRAWING IS UNPUBLISHED. RELEASED FOR PUBLICATION  
 © COPYRIGHT - By - ALL RIGHTS RESERVED.

LOC	DIST	REVISIONS					
AF	50	P	LTR	DESCRIPTION	DATE	DWN	APVD
		AG		REVISED PER ECR-12-013486	06JAN13	KH	KR

# SUGGESTED MATING TAB

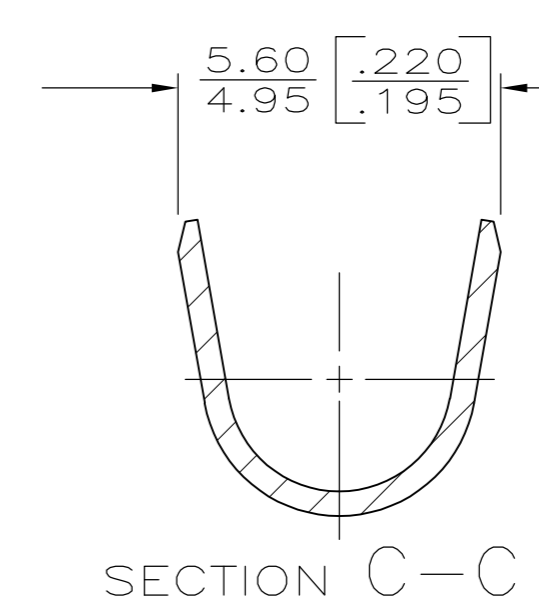
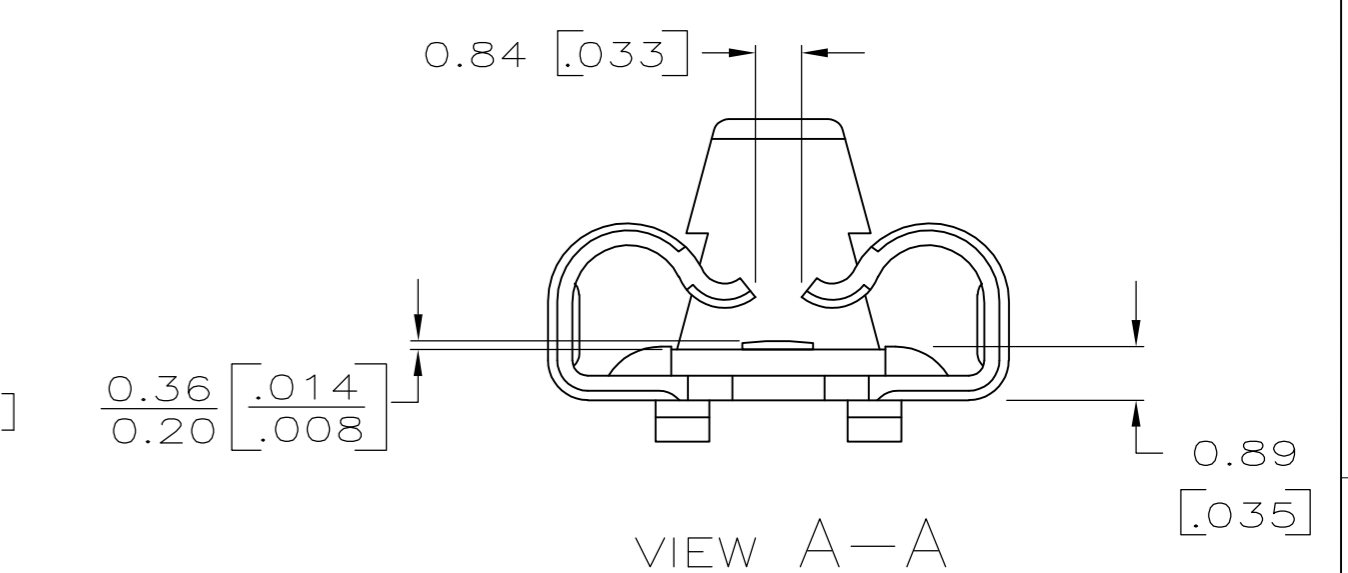
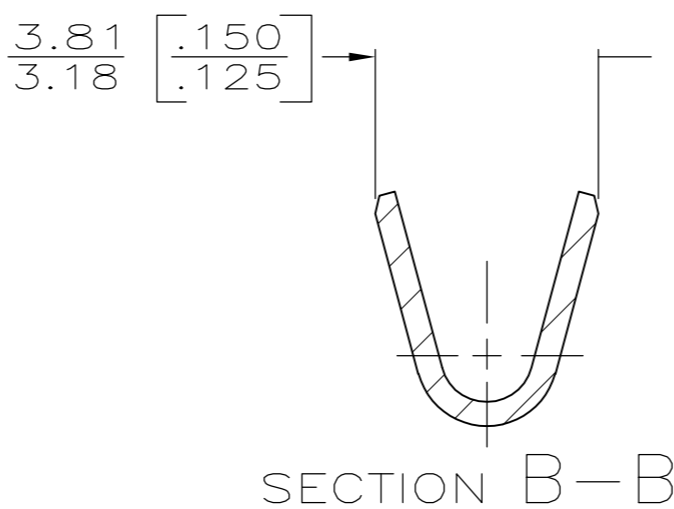
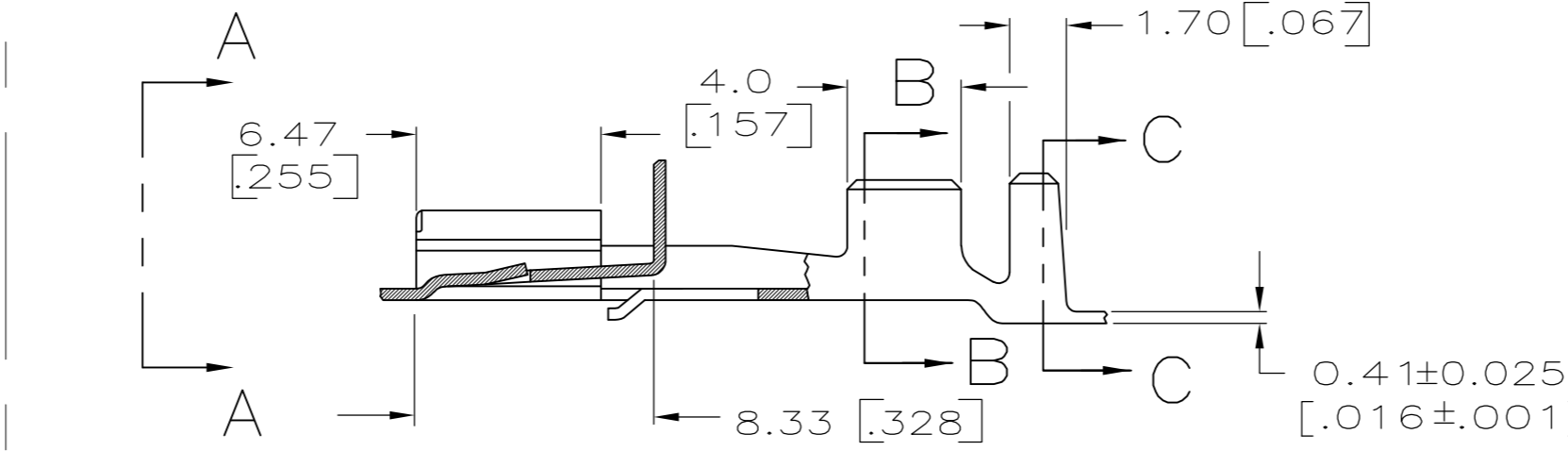
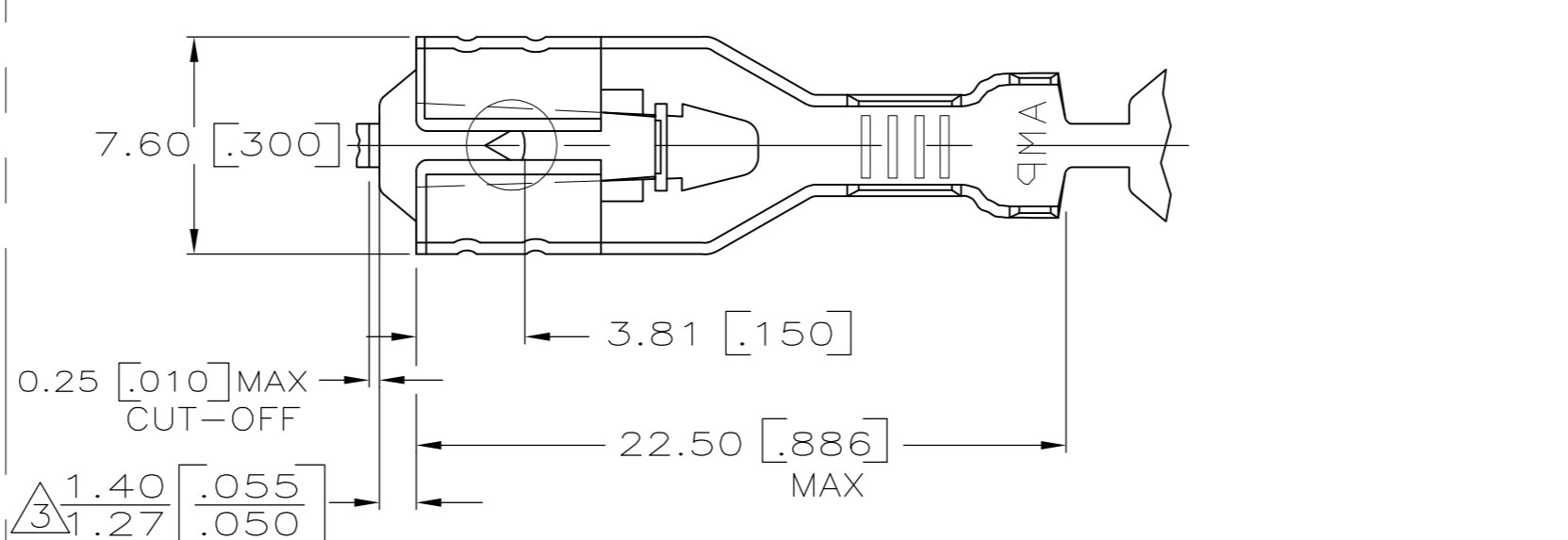
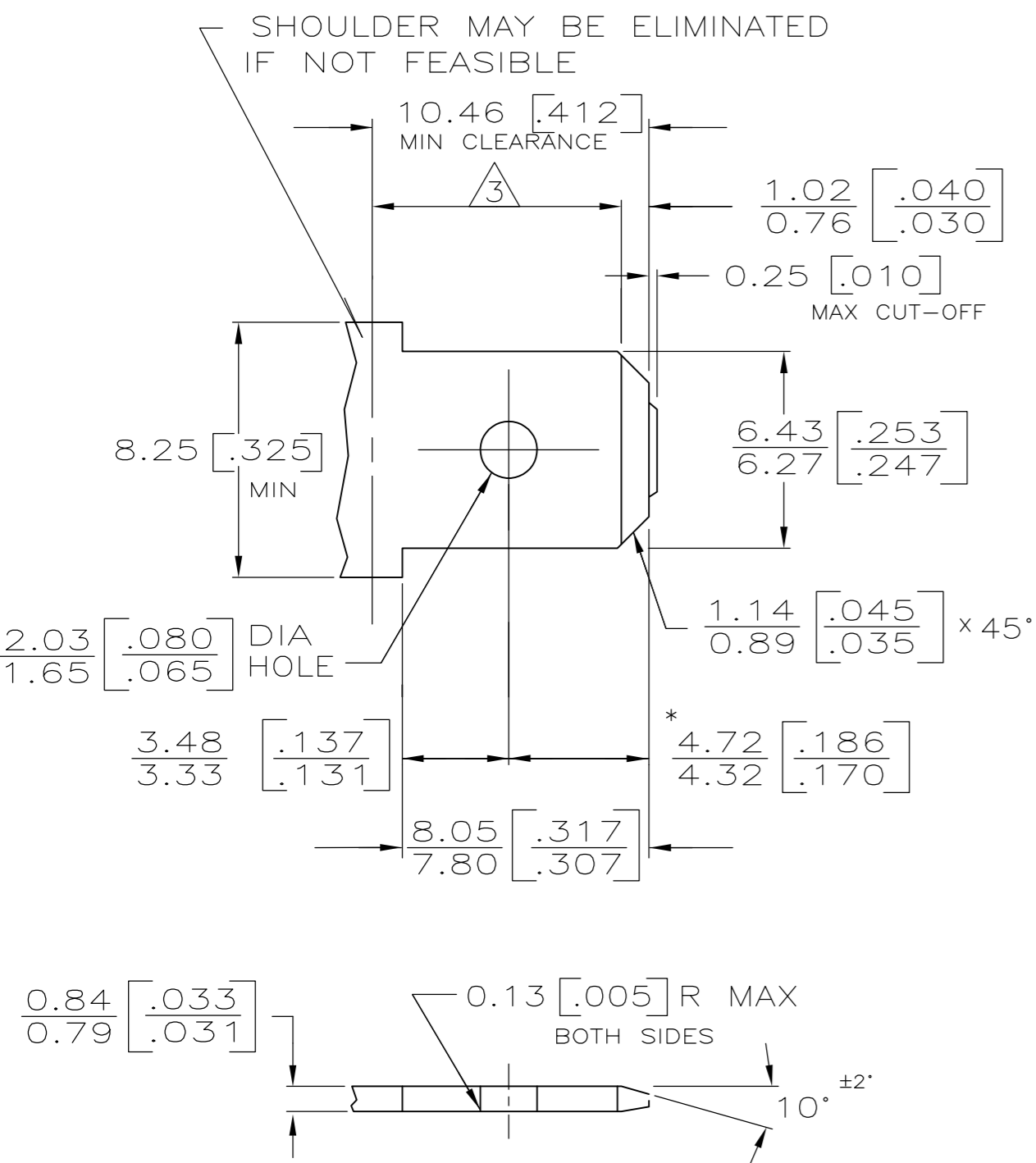

- 1 DIMENSIONS IN BRACKETS ARE IN INCHES.
- 2 PRODUCT PROVIDED IN STRIP FORM, BREAKS MAY BE PRESENT.
- 3 THE 1.40 [0.055] / 1.27 [0.050] DIMENSION MUST BE MAINTAINED BY THE APPLICATOR CUT-OFF TO ENSURE THE PROPER LOCKING FUNCTION OF THE RECEPTACLE.
- 4 LUBRICANT APPLIED AFTER TIN PLATING
- 5 STRESS RELIEVED
- 6 PRELIMINARY - NOT FOR PRODUCTION
- 7 OBSOLETE PARTS: OBSOLETE CIS STREAMLINING PER D.RENAUD/D.SINISI

- 1 MATL: 1/2H BRASS OR NICKEL PL STEEL.
  - 2 NO BURRS PERMISSIBLE AT HOLE.
  - 3 MUST BE FLAT WITHIN 0.076 [0.003] OVER THIS LENGTH.
  - 4 TIN PLATING IS REQUIRED ON BRASS WHEN TERMINAL TEMP. IS OVER 225°F
  - 5 HOLE MUST BE SYMMETRICAL ABOUT TAB Q WITHIN 0.076 [0.003]
- \* TO BE USED ONLY WHEN SHOULDER IS ELIMINATED.

FINISH	INSULATION RANGE	WIRE SIZE	PART NO.
7 OBSOLETE PRE-TIN	2.29-3.94 [.090-.155] DIA	[#18-#14] AWG	-63097-5
TIN PLATE	2.29-3.94 [.090-.155] DIA	[#18-#14] AWG	5 6 63097-4
7 OBSOLETE 4 TIN 0.002032 [.000080] MIN	2.29-3.94 [.090-.155] DIA	[#18-#14] AWG	63097-3
-	2.29-3.94 [.090-.155] DIA	[#18-#14] AWG	63097-2
TIN PLATE	2.29-3.94 [.090-.155] DIA	[#18-#14] AWG	63097-1

THIS DRAWING IS A CONTROLLED DOCUMENT.

DIMENSIONS: mm [INCHES]

TOLERANCES UNLESS OTHERWISE SPECIFIED:

0 PLC	± -
1 PLC	± -
2 PLC	± 0.25 [.010]
3 PLC	± -
4 PLC	± -
ANGLES	± -

MATERIAL: BRASS

FINISH: SEE TABLE

APVD: J GILLESPIE

PRODUCT SPEC: 114-2074

WEIGHT: -

CUSTOMER DRAWING

TE Connectivity

RECEPTACLE, POSITIVE LOCK, .250 SERIES

SCALE: 5:1

SHEET: 1 of 1

REV: AG